

DIN Rail Mounting Servo-Amplifier Module

Part Number	STE3050
Description	This DIN rail mounting servoamplifier module is intended for use in OEM applications where control circuitry already exists but a current amplifier is required to provide the final interface between controller and servovalve. Its compact design and ease of connection enables several of these modules to be mounted together where space is at a premium.
Overall Size	24mm wide x 100mm high (inc. terminal connectors) x 105mm deep (distance from DIN rail)
Connector	2 x 6 way removable terminal blocks.
Linear Gain	Link selectable and variable 1 – 1000 mA / V
Input	+/-10mA or +/-20mA (Specify when ordering)
Output	Up to 150 mA drive, overload + short circuit protection
Power Supply	+/-15VDC @ 50mA plus servovalve current
Environment	0 – 50 deg.C 20 – 80% RH operating
Compatability	TS32 or TS35 DIN Rail

Features Include

- User Selectable Output
- Compact Design
- Up to 150mA Current Drive
- DIN Rail Mounting
- Selectable Current Gain
- Overload and Short Circuit Output Protection
- Screw Terminal Connection
- Full Technical Support

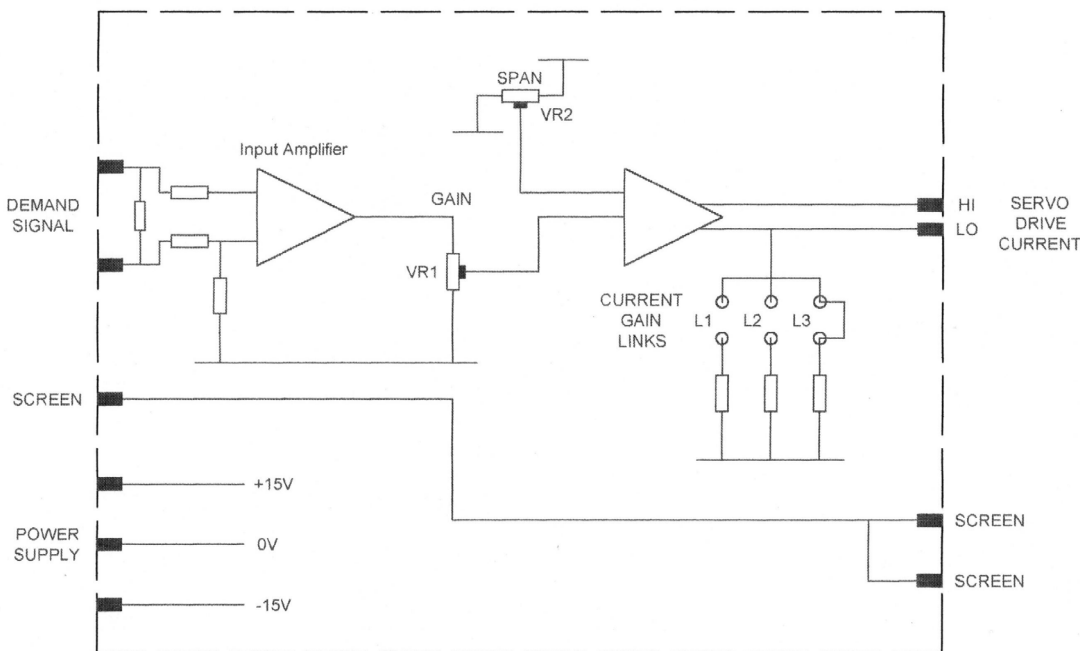

STE3050
Front View
(approx. full size)

